

SVF-Ex-300

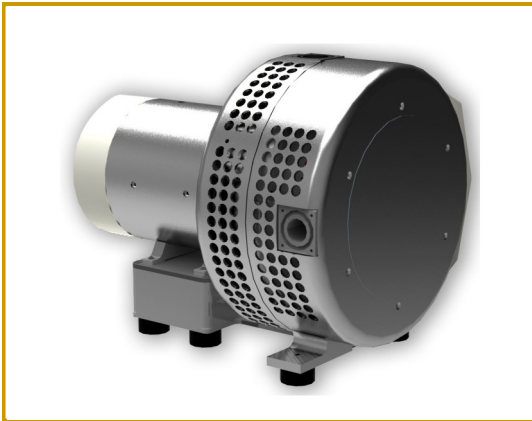

Similar Image

- ◆ Patent protected Floating Scroll Technology
- ◆ Maximum pumping speed of single unit is 18m³/hour
- ◆ For low and medium vacuum applications

Characteristics :

- ◆ Patent protected Floating Scroll Technology
- ◆ Uncontaminated flow
 No contamination of the media due to oil-free operation
 No tip seal or PTFE dust
- ◆ Maintenance-free
 No tip seal or other parts needing periodic replacement
- ◆ High performance
- ◆ Long product life
- ◆ High level of gas tightness
- ◆ Very quiet and low vibration
- ◆ Can operate in any installed position
- ◆ Startup against air or vacuum

Dimensions:

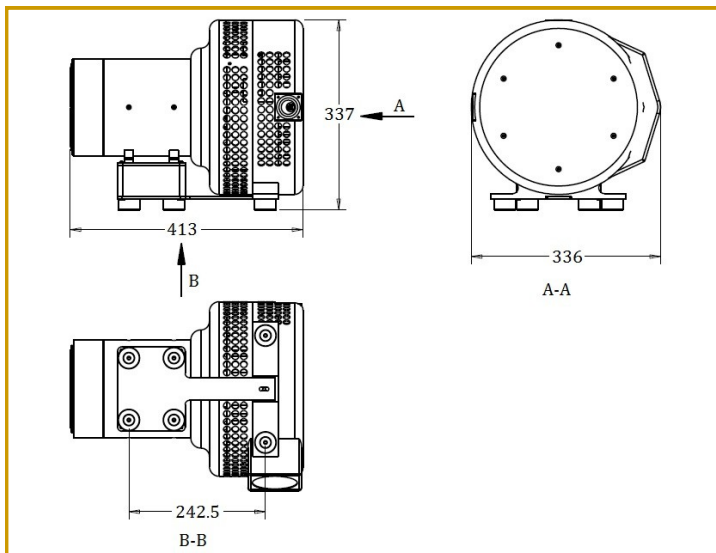

Pumping speed:

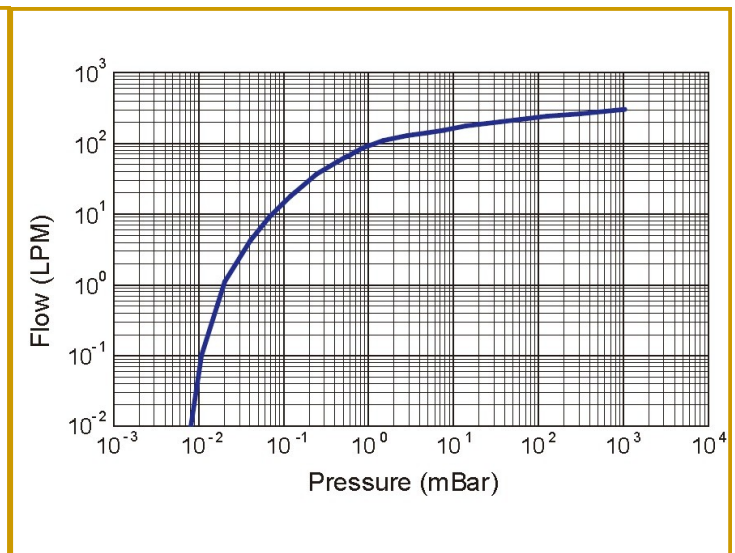

Technical Data	SVF-E0-300	SVF-E2-300	SVF-E3-300
Pumping Speed	300L/min (18m ³ /hr)	300L/min (18m ³ /hr)	300 L/min (18m ³ /hr)
Ultimate pressure	≤ 1.0 mBar(100Pa)	≤ 0.01 mBar(1Pa)	≤ 0.001 mBar(0.1Pa)
Power consumption, Max.	0.75 kw	0.75 kw	0.75 kw
Motor type	Brushless DC Motor	Brushless DC Motor	Brushless DC Motor
Voltage	48 VDC Or 110-220 VAC	48 VDC Or 110-220 VAC	48 VDC Or 110-220 VAC
Maximum speed	3,000 RPM	3,000 RPM	3,000 RPM
Noise level	60 dB(A)	60 dB(A)	60 dB(A)
Weight	22 kg/ 48.4 lb	22 kg/ 48.4 lb	22 kg/ 48.4 lb
Dimensions (with case) L × W × H	413×338×338 mm	413×338×338 mm	413×338×338 mm
	16.26×13.3×13.3 inch	16.26×13.3×13.3 inch	16.26×13.3×13.3 inch
Inlet connection	KF 25	KF 25	KF 25
Outlet connection	KF 25	KF 25	KF 25
Cooling system	Air Cooled	Air Cooled	Air Cooled
Ambient temperature	-40°F To 104°F	-40 °F To 104°F	-40°F To 104°F
	-40°C To 40°C	-40°C To 40°C	-40°C To 40°C

Contact us:

Company	Phone	Email	Address
Scroll Laboratories, Inc.	+1-630-783 2608	Infousa@scrolllabs.com	479 Quadrangle Drive, Unit G, Bolingbrook, IL 60440, USA