

## SVF-5

## Miniature Dry Floating Scroll Vacuum

- Patent protected Floating Scroll Technology.
- 100% oil free .
- Maintenance free.
- Compact size ideal for portable equipment.

### Applications

Analytical instrumentation , laboratories , backing pump for turbo pumps, practically in all areas in which clean vacuum is needed .

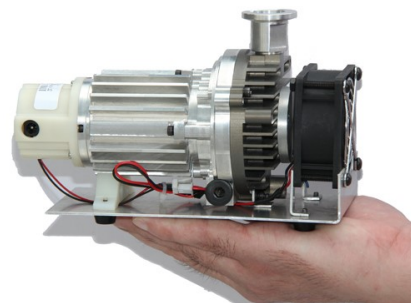

## Technical Data

Model	SVF-E0-5	SVF-E1-5
Pump Speed	5 L/min	5 L/min
Ultimate Pressure	$\leq 1$ mbar (100 Pa)	$\leq 0.1$ mbar (10 Pa)
Motor Power	20 W	20 W
Installed Power	15 W	15 W
Motor Type	Brushless DC Motor	Brushless DC Motor
DC Voltage	12 VDC	12 VDC
AC Voltage (with adapter)	100 - 240 VAC	100 - 240 VAC
Maximum Speed	3600 RPM	3600 RPM
Vapor Tolerance	Unlimited	Unlimited
Maximum Inlet Speed	Unlimited	Unlimited
Maximum Outlet Speed	1 barg	1 barg
Noise Level	56 dB(A)	56 dB(A)
Weight (OEM)	1.1 kg	1.11 kg
Weight (With Base)	1.7 kg	1.7 kg
Dimensions (OEM)	182×88×94mm	182×88×94mm
Dimensions (With Base)	186×132×119mm	186×132×119mm
Inlet/Outlet Connection	G 1/8"	G 1/8"
Cooling System	Air - Cooled	Air - Cooled
Ambient Temperature	-40°C to 50°C	-40°C to 50°C

# Pumping Curve

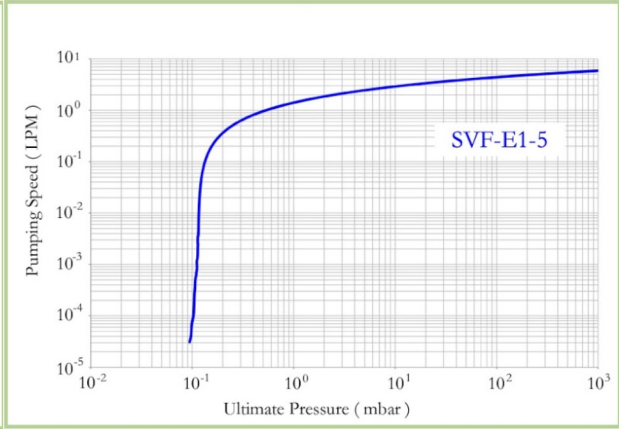
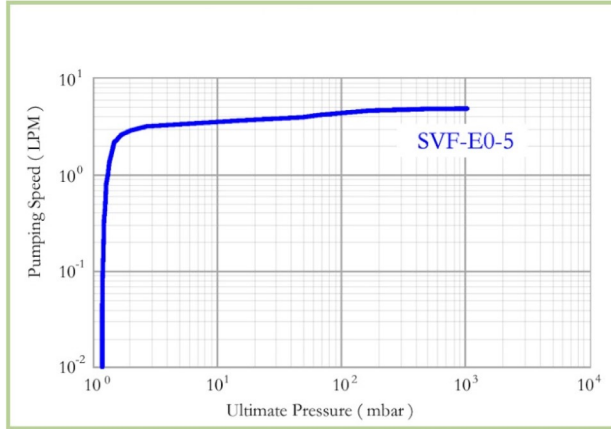

# Dimensions (mm) & Product Image

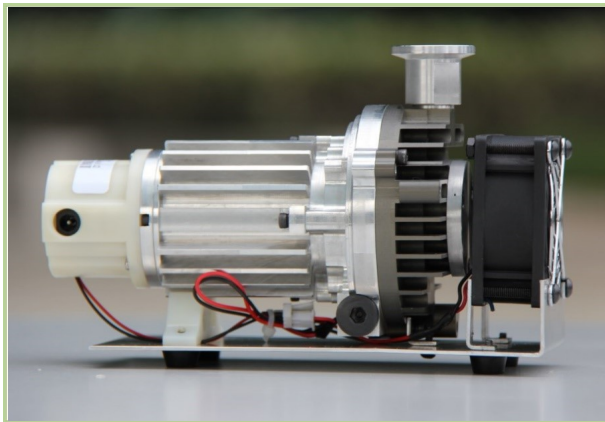
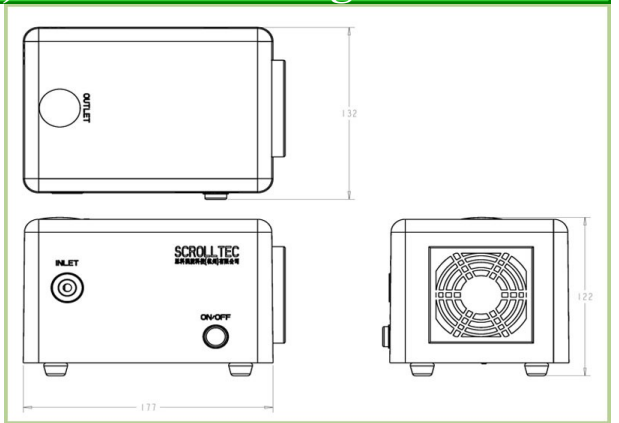
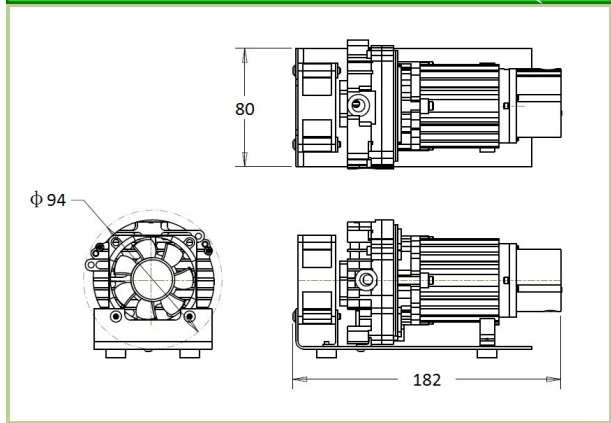

**Scroll Labs<sup>®</sup>**  
 Innovative Oil-Free  
 Floating Scroll Technology

Website: [www.scrolllabs.com](http://www.scrolllabs.com)  
 Phone: +1 (630) 783-2608  
 Fax: +1 (630) 783-2609  
 Email: [infousa@scrolllabs.com](mailto:infousa@scrolllabs.com)  
 Address: 479 Quadrangle Drive, Suite G,  
 Bolingbrook, IL 60440, USA